

bhi

**NEDSP1061 Noise Reduction Module  
Yaesu FT-817 Version  
Fitting Instructions**

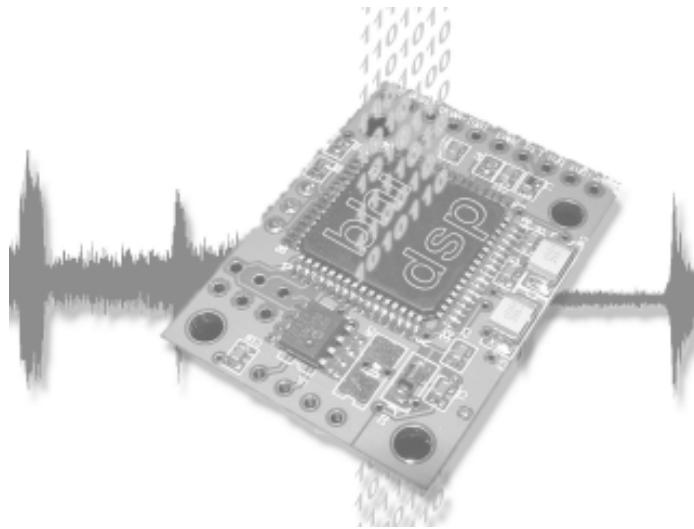

bhi

1061-104D  
Issue B

# 1. Introduction.

The bhi NEDSP1061 noise reduction module is a fully integrated solution for noise reduction on the Yaesu FT-817.

## Features:

- 4 Levels of noise cancellation (up to 35dB)
- Single Button operation
- Visual and audible indication of operation
- Low power consumption
- Retains the internal battery pack
- Fully integral installation
- Stores the last used filter level.
- Automatic tone reduction (upto 65dB)

## Specifications:

White noise reduction:

level 1	11dB
level 2	13dB
level 3	19dB
level 4	35dB

Tone reduction:

level 1	5dB
level 2	8 dB
level 3	21dB
level 4	65dB

Current consumption: 45mA

# 2. Disclaimer

Installation of this product will invalidate your warranty. This product must only be installed by those who are technically competent. The assembly involves the removal of small surface mount components and the drilling out of the transceivers' lid. It is assumed that the installer has the necessary experience and knowledge to work on equipment of this type.

Failure to follow these instructions may cause damage to the equipment bhi will not accept liability for damage to the equipment caused by fitting this module.

All attempts have been made to ensure that this information is up to date. It is possible that these instructions contain errors, the equipment is slightly different to the one used to compile this information. In all cases it is up to the installer to ensure that the module is fitted correctly.

By installing this module you are doing so at your own risk.

### 3. Installation.

This document should be read in conjunction with the Yaesu FT-817 technical supplement. Remove any fitted batteries or NiCad pack before commencing installation.

The bhi NEDSP1061 module is inserted into the audio path of the transceiver, at a point before the volume control. To access this point it is necessary to remove the main unit.

Remove the top and bottom covers.

Remove the 5 main unit fixing screws.

Disconnect all connections - apart from the front unit ribbon cable.

Hinge the main unit forward, over the front unit ribbon cable.

To place the module into the audio path it is necessary to remove capacitor C1338. The following diagram shows the position of the component.

Carefully remove the capacitor.

Connect the screened lead from the NEDSP1061 module as follows:

Red lead - to R1482 side of C1338 (audio in)

Blue lead to the other side of C1338 (audio out)

Screen to the grounded connection close to the capacitor.

See the following diagram for details.

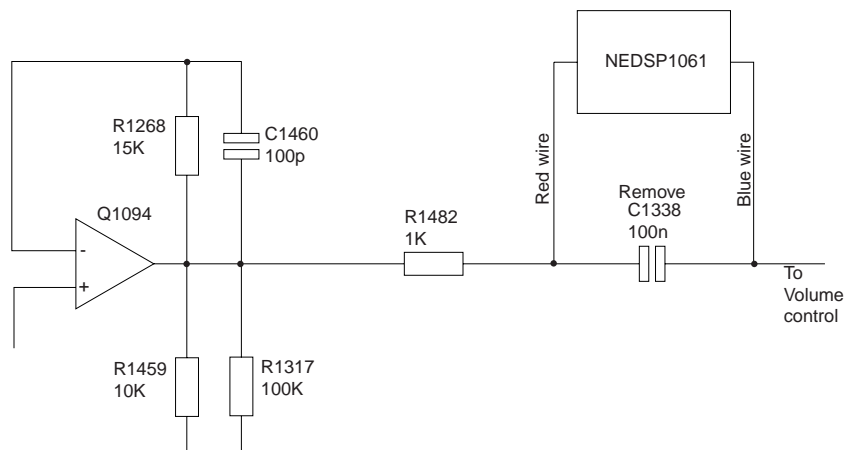

Schematic detail. FT-817

Location of  
C1338  
on lower side  
of main unit

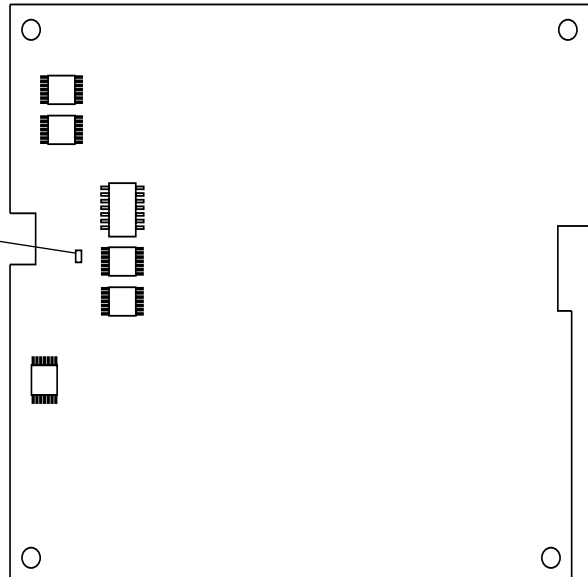

Location of  
Q1082 (TP1084)  
on upper side  
of main unit

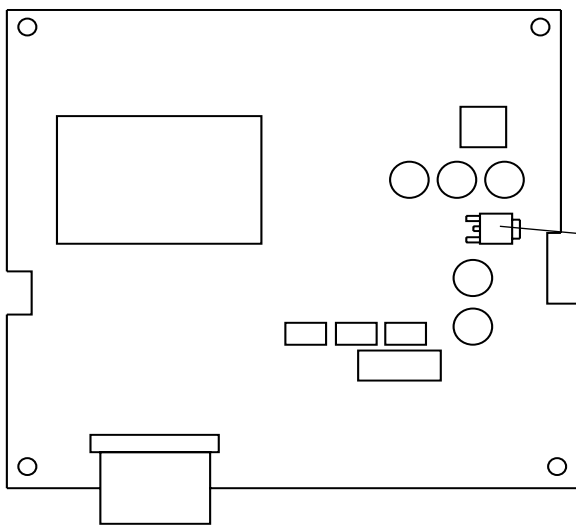

Q1057

Lower side of main unit

Screen

Blue wire

Red wire

R1482

Q1084

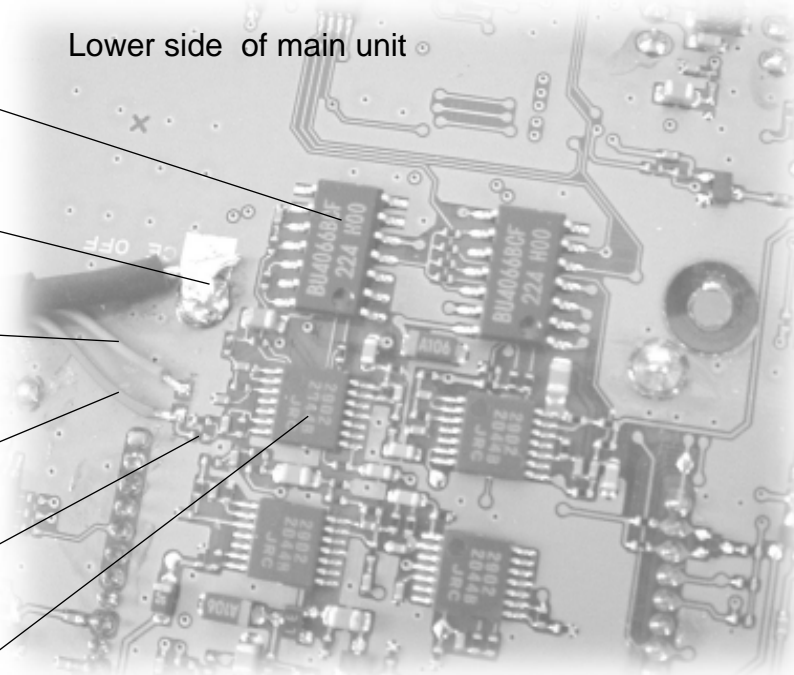

NEDSP1061 screened lead connection detail

Replace the main unit PCB.

The NEDSP1061 screened lead fits in the cut out provided for the front antenna connector.

Replace the main unit, connections, and all screws except the front right hand screw.

Drill the holes for the lid, as per the drawing at the back of this document.  
Using hot melt adhesive affix the small keyboard to the inside of the lid. Taking care to not get adhesive on the lid, switch or LED.

Allow this to cure before continuing.

The NEDSP1061 can be affixed in two positions.  
The preferred position is in the location of the optional filter. This provides the more mechanically secure location. If the optional filter is (or is going to be) installed the module can be installed along side the filter.

Solder the red (power) lead to the drain of Q1082 (TP1084).  
Connect M3 ring tag (0V leads) using the right front screw.  
Affix the NEDSP1061 module using the supplied self adhesive pad in the chosen location.

See the following diagram.

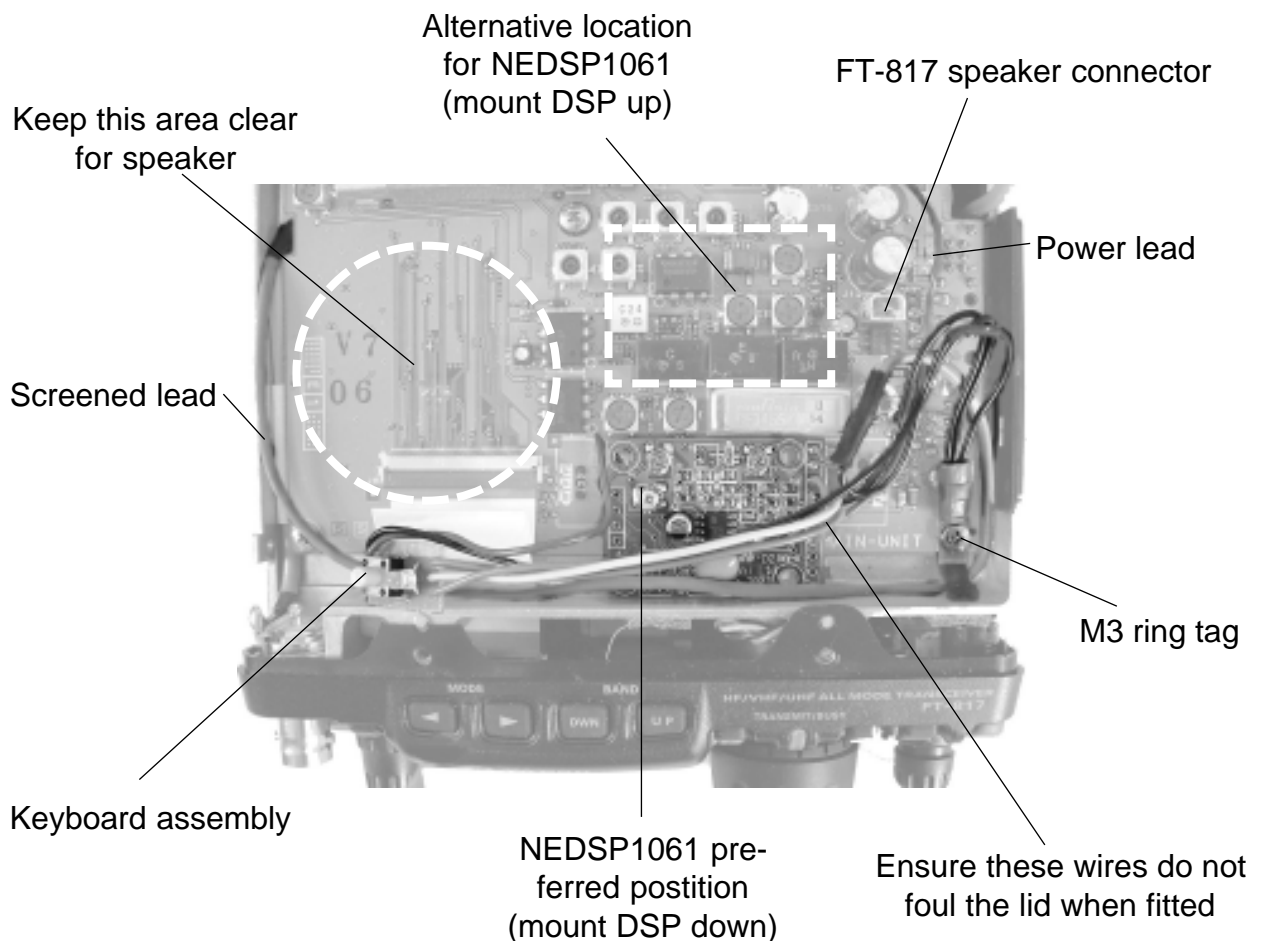

## 4. Adjustments

The NEDSP has three adjustments:

- Input signal level
- Output signal level
- Beep volume

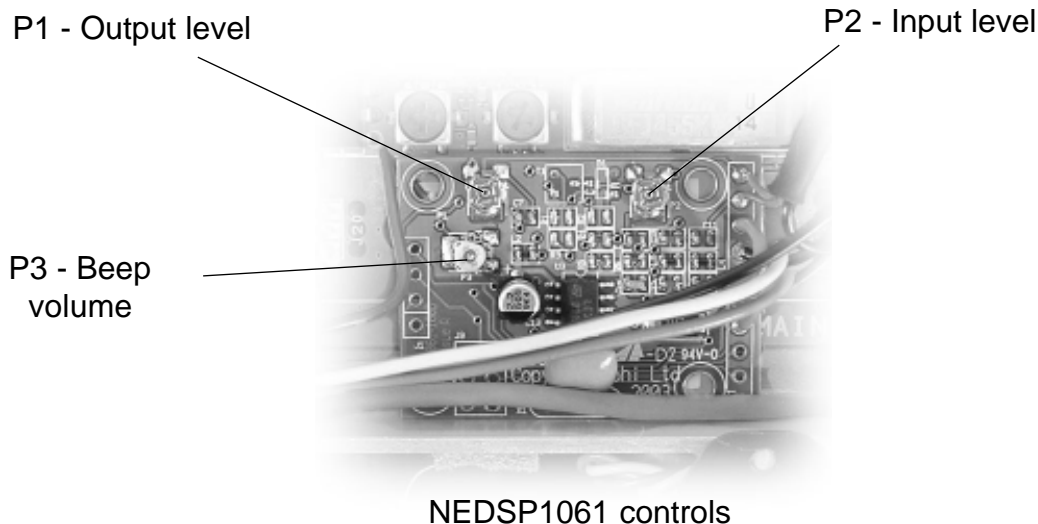

The input and output levels do not normally need to be adjusted (see troubleshooting section). Rotating anticlockwise will increase the level.

The beep volume can be adjusted to suit the user. Rotating P3 anti clockwise will increase the beep volume.

The beep can be disabled, by turning the volume control fully clockwise.

Ensure all connections are replaced.

Place the lid loosely over the FT-817.

Connect an antenna.

Switch on.

Detune the FT-817 to receive static.

Press and release the DSP button, the unit will beep to indicate which filter level is selected ( 1 beep for level 1, 2 for level 2 etc.).

The led will also flash in green at the same time. The noise level will now be reduced.

Press the button again and the noise cancellation will be switched off, and the LED illuminate red.

If the unit operates correctly then replace the lid. Affix the supplied label over the switch and LED.



## 5. Troubleshooting.

**Problem:**

The volume of the FT-817 can be increased up to a point - where it then starts to fall.

**Cause:**

Input level to the NEDSP1061 is too high and causing the DSP input circuit to clamp.

Reduce the signal input level using P2.

**Problem:**

Increasing the volume to the FT-817 creates distortion.

**Cause:**

Output level from the NEDSP1061 is over driving the FT-817 power amplifier.

Reduce the output level using P1.

**Note:**

When listening high noise/signal broadcasts it is possible for the DSP to create an effect that resembles slight clipping. Always check clipping problems with a good quality clean audio signal, such as an FM talk station.

# NEDSP1061 Noise Reduction Module Yaesu FT-817 Version Operating Instructions

## Features:

- 4 Levels of noise cancellation (up to 35dB)
- Single Button operation
- Visual and audible indication of operation
- Low power consumption
- Retains the internal battery pack
- Fully integral installation
- Stores the last used filter level.
- Automatic tone reduction (upto 65dB)



## 1. Introduction.

The NEDSP1061 module features is a fully integrated solution for noise reduction for the Yaesu FT-817.

## 2. Operation.

All functions of the NEDSP1061 are controlled by a single button.

- Single press turns the noise cancellation on/off.
- Holding down the button changes the DSP filter level.

The mode of operation is indicated both visually and audibly. The LED is illuminated red when the noise cancellation is off.

When the noise cancellation level is changed the LED will flash green to indicate which level has been selected.

Simultaneously the DSP will beep to give audible indication of DSP level. This allows the operator to change the DSP level without having to look at the LED to see which level has been selected.

A short beep is emitted to acknowledge a button press.

The module will store the current DSP level, and will return to this level when the FT-817 is switched on.

## 3. Use.

Switch on the FT-817.

The LED will illuminate red to indicate the noise cancellation is off. The unit will flash/beep to indicate the DSP filter level last used.

### Noise cancellation on/off.

Press and release the button and the led will extinguish, and the noise cancellation will be activated.

### Changing the filter level.

Hold down the button. The led will flash the filter level, and if the button is held it will step through all the levels. When the desired level has been reached release the button. This new value will be stored in the modules' memory.

#### 4. Demonstration mode.

The NEDSP1061 module features 2 preset demonstration modes. These demonstrate the noise cancellation abilities of the NEDSP1061 module.

##### Demonstration 1:

Hold down the button and switch on the FT-817. After a short time the unit will emit a 2 tone beep. Release the button. The unit is now in demonstration mode 1.

The module will switch the noise cancellation on for 1.5 seconds, then off for 1.5 seconds.

It will then move onto the next level and repeat this continuously through all 4 levels.

This mode is particularly effective when the FT-817 is just receiving static, as it demonstrates the attenuation of white noise at all the levels.

Alternatively tune the FT-817 into a good quality FM speech broadcast. This demonstration shows how little the DSP alters the speech, at any of the levels.

##### Demonstration 2:

Follow the procedure as above. Wait for the second 2 tone beep, then release the key.

In this mode the filter level is set to level 3.

The noise cancellation is switched on for 3 seconds, then off for 3 seconds. This loops until the user aborts this mode.

This is a good demonstration for listening to noisy SSB conversations showing the before and after.

##### Exiting the demonstration mode.

Hold down the button until the 2 tone beep is heard. Release the button.

After a short delay the LED will flash indicating the stored level, as during the normal switch on.

#### 5. Notes about the noise reduction.

When using the module on level 4 strange “watery sounds” may be heard. This is quite normal when listening to high levels of noise at level 4.

#### 6. Specifications.

Description	
White Noise Attenuation	Level 1 11dB Level 2 13dB Level 3 19dB Level 4 35dB
Tone reduction	Level 1 5dB Level 2 8dB Level 3 21dB Level 4 65dB
Voltage	5 - 15 Vdc
Current consumption	45mA
PCB size	26 x 37mm

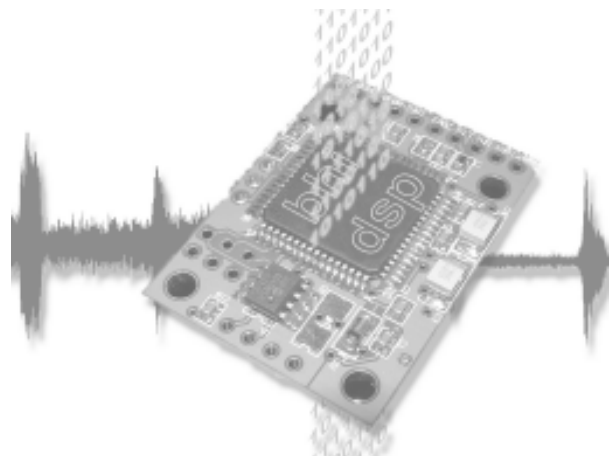

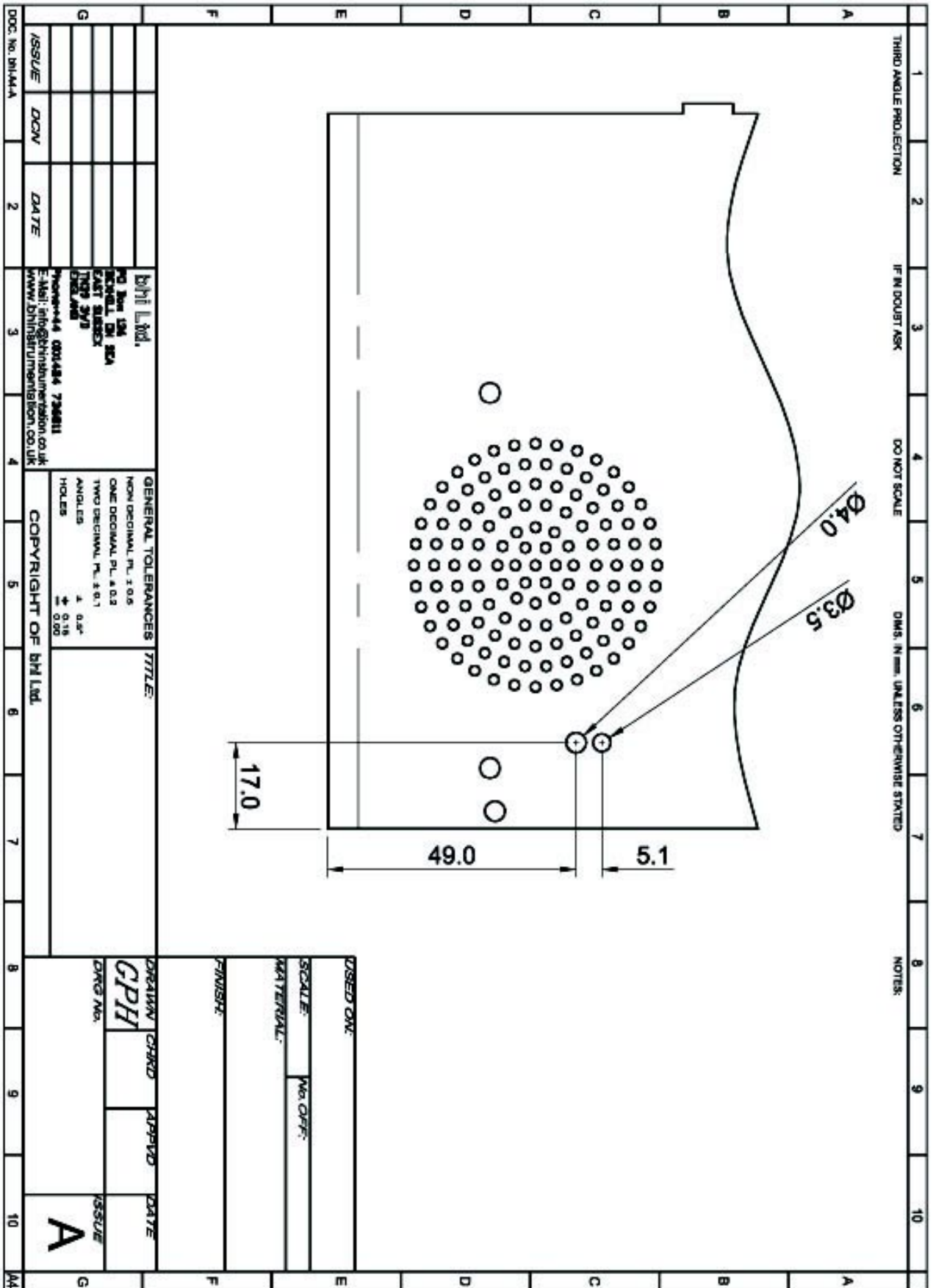

**bhi Ltd**  
P.O.Box 136  
Bexhill on Sea  
East Sussex  
TN39 3WD

Tel: 0870 240 7258  
Fax: 0870 240 7259